

RVC 400 Rotary Vibration System

Systems
&
Solutions

Engineered
vibration testing
solutions for
improved
product quality.

Team Corporation
11591 Watertank Road
Burlington, WA 98233
(360) 757-8601
Fax: (360) 757-4401
sales@teamcorporation.com
www.teamcorporation.com

Team Corporation UK
Team Corporation UK Ltd
11 Old Ladies Court
High Street
Battle
East Sussex
TN33 0AH
United Kingdom
Tel: +44 (0) 1424 777004
Fax: +44 (0) 1424 777005
sales@teamcorporation.co.uk
service@teamcorporation.co.uk
www.teamcorporation.co.uk

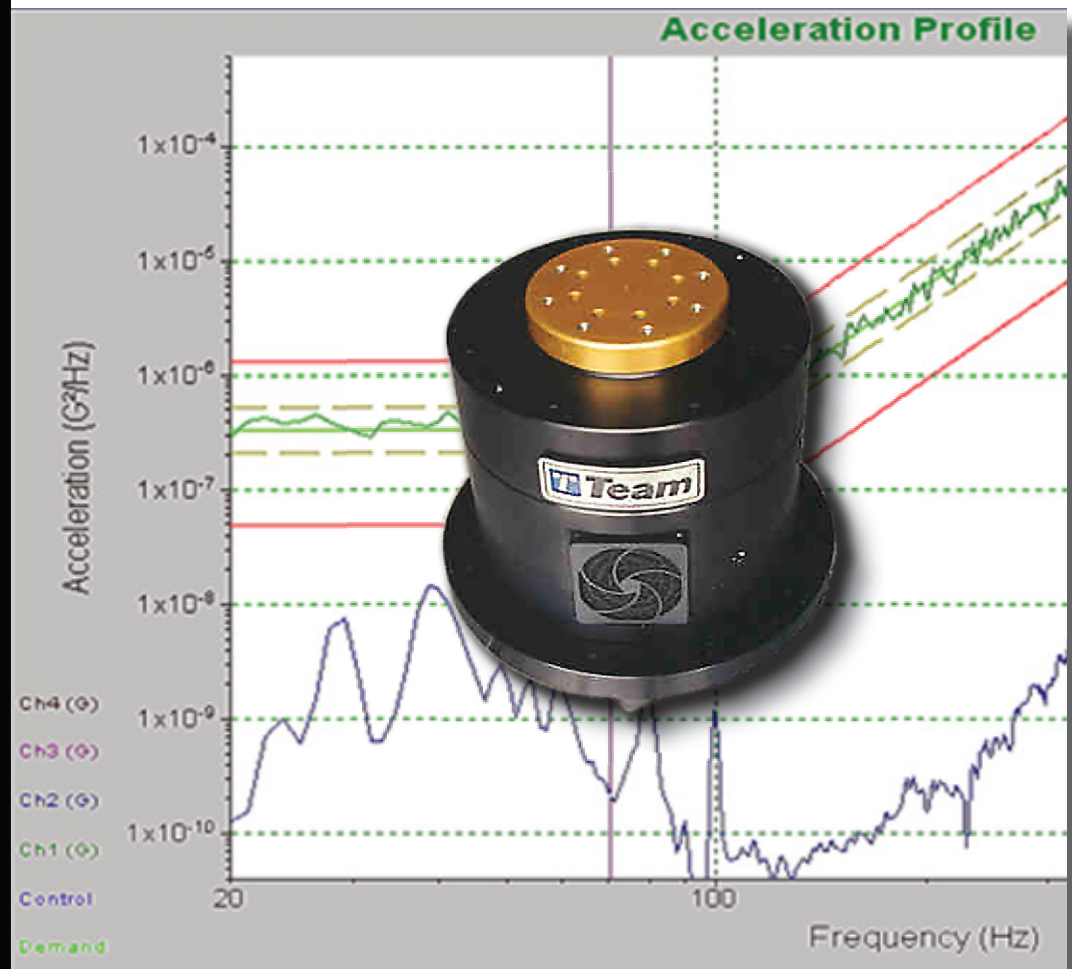

RVC 400 Rotary Vibration System

A wide variety of equipment manufacturers are requiring rotary vibration and shock testing from their suppliers. Accurately achieving the test levels needed is a significant challenge for quality engineers. Cross-axis motion, total harmonic distortion and shock pulse shaping are important test parameters difficult to control. *Team* Corporation, a recognized leader in high-performance vibration test equipment, has a device specifically designed to address these needs of computer, sensor and disk drive manufacturers.

The RVC400 was designed by *Team* Corporation to create controllable torsional vibration and shock, all in a compact, quiet device suitable for use in a standard office or laboratory setting. Capable of frequency response to 2 kHz, the RVC400 can provide clean rotary sinusoidal and random profiles as well as limited shock pulses on small test objects. Coupled with any commercial single axis controller, quality engineers now have the speed and precision in vibration test and analysis to perform their demanding tests.



The RVC400 is an electrically powered device. The basis of the design is a state-of-the-art torsional voice coil directly driving a flexure bearing supported rotary shaft and table. This arrangement provides a very responsive rotating mechanism with virtually no friction yet retains the ability to react off-axis motions with very little deflection. Utilizing rare earth permanent magnets, this rotary drive produces very high torque within a small dimensional envelope.

The efficient design of the RVC400 eliminates the need for external blowers to maintain the optimum operating temperature range. An integral fan is all that's needed to provide adequate cooling in a typical laboratory environment. This feature reduces the cost of installation and operation. Additionally, it greatly reduces the noise level typically associated with conventional testing.

Features:

- Perform swept sine at levels up to 3,000 rad/sec²
- Create shaped random profiles
- Dynamically control shock profiles
- Precision through 2 kHz with less than 15% cross-axis distortion
- Compact
- Quiet
- Suitable for use on your desk top and in environmental chambers
- Proven to meet the rotational vibration requirements defined in Dell's OEM/Third Party Lab Certification Procedure

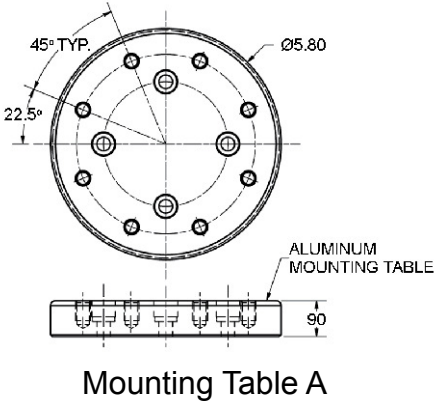

Mounting Table A

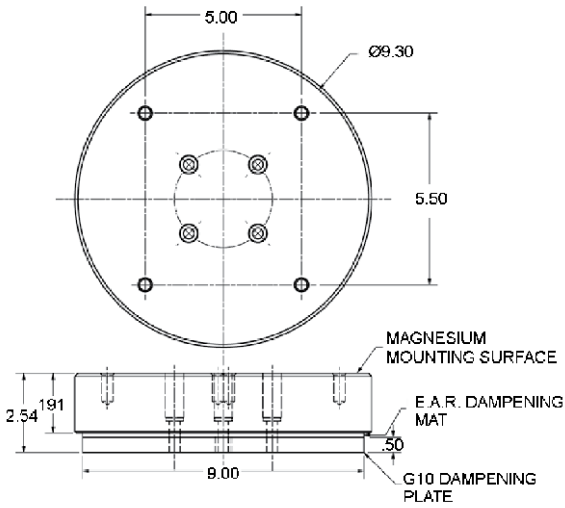

Mounting Table B

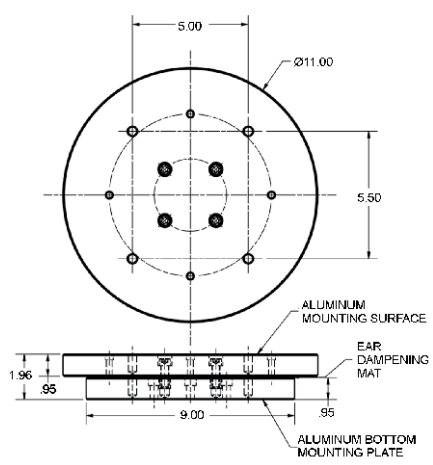

Mounting Table C

Screen capture of graph showing Mounting Table Option "A". Trace shows .5g sine sweep to 3 kHz. Accelerometer mounted at 2.5" radius.

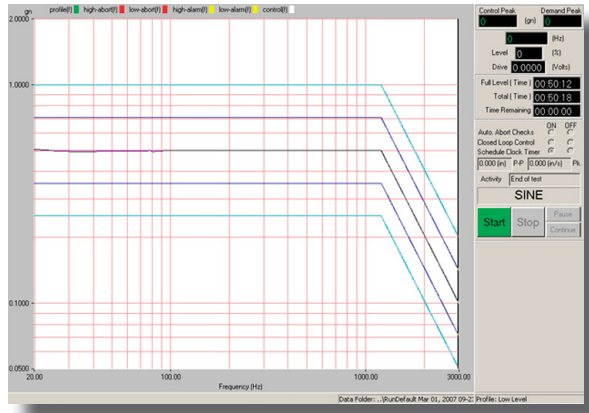

Graph shows data capture with Mounting Table Option "B". Blue trace shows off-axis vertical acceleration driving a random vibration test to 2,000 Hz. Lower red abort limit equals 15% of demand.

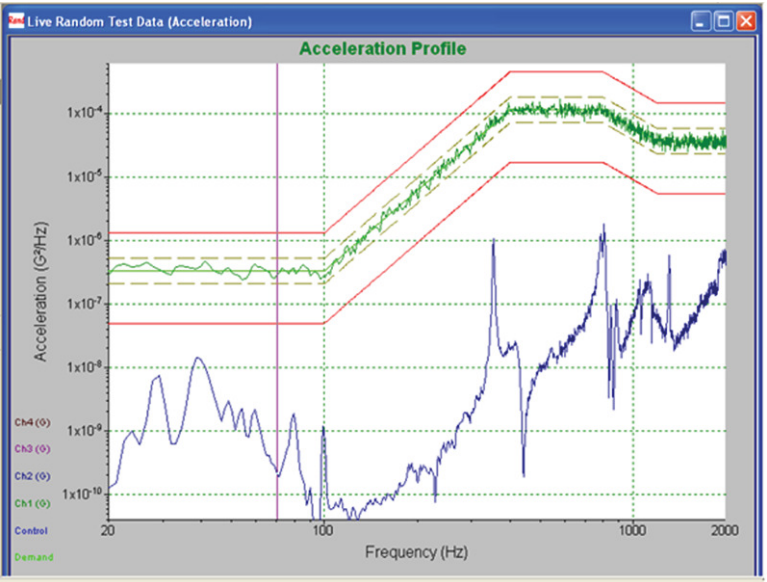

Specifications

Frequency Range
Max Displacement

Peak Torque
Continuous Torque

Bare Table
with Top Plate removed

Payload rotational inertia of 0.02 in-lb-sec²
Payload rotational inertia of 0.05 in-lb-sec²
Payload rotational inertia of 0.08 in-lb-sec

Payload rotational inertia of 0.05 in-lb-sec²
with Top Plate removed

Table Diameter
Shipping Wt. (approx.)

TABLE A	TABLE B	TABLE C	Units
10 - 2000	10 - 2000	10 - 2000	Hz
20	20	20	degrees Pk-Pk
Torque (220 VAC Input)			
400	400	400	in-lb
134	134	134	in-lb
Max angular acceleration (220VAC Input)			
3000	1425	677	rad/sec ²
		1600	rad/sec ²
Shock Performance - 1/2 Sine, 1 ms (110VAC Input)			
2500	1333	655	rad/sec ²
1900	1200	625	rad/sec ²
1250	1100	600	rad/sec ²
Shock Performance - 1/2 Sine, 1 ms (220VAC Input)			
4000	2400	1250	rad/sec ²
		2600	rad/sec ²
5.8	9.0	11.0	inches
90	95	100	lbs

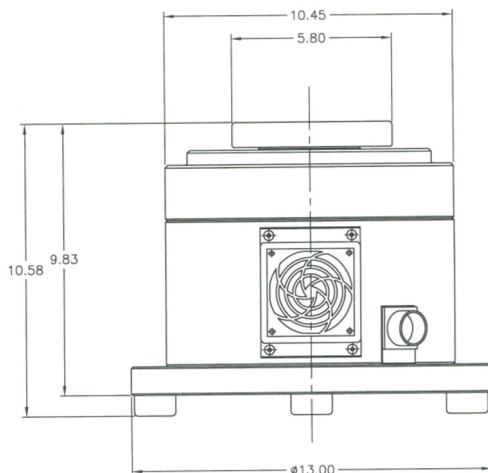

Shaker dimensioned with
mounting table "A"